

UMI (Universal Metering Interface)

Overview



Cambridge Consultants Ltd
Science Park
Milton Road
Cambridge
England CB4 0DW

Tel +44 (0)1223 420024
Fax +44 (0)1223 423373
Registered No: 1036298 England

Cambridge Consultants Inc
101 Main Street
Cambridge MA 02142
USA

Tel: +1 617 532 4700
Fax: +1 617 737 9889
info@CambridgeConsultants.com
www.CambridgeConsultants.com

UMI and the UMI logo are trademarks of Cambridge Consultants Ltd.

Subject: UMI™ (Universal Metering Interface) Overview

1	Introduction	3
2	UMI Open Standard	3
3	Technical	4
3.1	Topology and Power	4
3.2	Mechanical	6
3.3	Electrical	6
3.4	Link and Application Layers	7
3.5	Security	7
3.6	UMI codes and data objects	8
4	UMI Certification	9
5	Benefits	9
5.1	Device Manufacturers	9
5.2	Energy Suppliers	9
5.3	Smart meter rollouts	9
6	What next ?	10

Subject: UMI™ (Universal Metering Interface) Overview

1 Introduction

UMI (Universal Metering Interface) is a new low power board-to-board wired interface. UMI (pronounced ‘you-me’) has been developed by Cambridge Consultants. UMI is primarily aimed at smart metering :

- Meters (Electricity, Gas, Water, Heat)
- Displays
- Gateways
- Appliances
- Communications modules (wireless and wired) for all the above products

Many smart metering product developments are being held up because the communications standards have not yet been finalised by the relevant national authorities. UMI solves this problem by separating the metrology and communications functions into modules with a wired connection between them. This unbundling is useful because the metrology standards and regulations (e.g MID in Europe) are stable. It allows the same approved base meter (or display or gateway or appliance) to be used with different communications modules from one energy supplier or country to another.

Manufacturers can also develop smart-ready MID-approved meters now by including one or more UMI ports. These meters can be installed in the field now, without a communications module fitted. When the communications standard is chosen (for that region or installation), the appropriate UMI communications module can be fitted to the meter (or gateway or display or appliance) in the field.

UMI is aimed at ultra low power applications. Typical battery-powered products may have an average current consumption of 15uA at 3V.

UMI has already been adopted by :

- Elster in domestic gas meters.
- Telegesis in ZigBee modules.

If you would like to implement a UMI port in your product or communications module, you can get more information from :

- www.CambridgeConsultants.com/umi

2 UMI Open Standard

UMI is an open standard. At present Cambridge Consultants is the caretaker for UMI (members, licence agreements, specifications, approvals, logo, trademarks, etc). In future these responsibilities will be taken over by the independent UMI Alliance.

Principles for UMI are :

Subject: UMI™ (Universal Metering Interface) Overview

- There are no licence fees for using UMI.
- UMI specifications are available.
- UMI should be implemented in full, not in part.
- UMI is tightly controlled to prevent divergence. All UMI Peripherals must work with all UMI Hosts (subject to; low and high power variants, data object access rights, security keys).

UMI software stacks and test services are available from Cambridge Consultants. We expect these to also be available from other suppliers in future.

3 Technical

The UMI specification (UMI-S-001) maps UMI to the OSI 7-layer communications model. It provides a full definition :

- Mechanical
- Electrical (SPI signals at 2.7V-3.6V over 10-IDC connector)
- Logical :
 - Link layer packets
 - Application layer packets
 - Access Control
 - Security
 - Data objects and UMI codes

3.1 Topology and Power

UMI has a star network topology like USB. UMI has much lower power consumption than USB. UMI operates rather like a ruggedised version of the SD card interface.

There is one UMI Host which can connect to 0-15 UMI Peripherals. The UMI Host is always powered and contains a UTC real time clock. The Host has a separate 10-IDC connector for each UMI Peripheral :

- Female for direct board-to-board connections.
- Male for indirect connections via ribbon cable.

The UMI Host has one UMI Port for each UMI Peripheral. UMI Ports can be high power (1A at 5V) or low power (50mA at 3V). The UMI Host can have any mixture of high power and low power UMI Ports. A battery-powered device such as a gas meter will only contain low-power UMI Ports. A mains-powered device such as an electricity meter or a gateway may contain high-power and low-power UMI Ports.

There are three types of UMI Peripheral :

- High power. Can only be plugged into a high-power UMI Port. Peak power is 1A at 5V from UMI_HVDD. This could be a GSM module (GPRS or SMS).

Subject: UMI™ (Universal Metering Interface) Overview

- Low power. Can be plugged into a low-power or high-power UMI Port. Peak power is 50mA at 3V from UMI_VDD. This could be a ZigBee, KNX, Z-Wave, Wavenis, Bluetooth or Wireless M-Bus module.
- Self powered. Can be plugged into a low-power or high-power UMI Port. This could be Wired M-Bus, Wired KNX, PLC (power line communications) or a battery powered GSM module (that could be used in a gas meter).

The connector & physical form factor are the same for all the above UMI Peripheral types. High power UMI devices connect the UMI_HVDD pin, others do not.

The Host provides a switched power supply to each Peripheral. The signal level is defined by UMI_VDD. UMI_VDD is also used as the power supply in low power UMI Ports. UMI_HVDD is used as the power supply in high power UMI Ports. The Host must turn the power supply off when a Port is unused and when a Peripheral is changed (unplugged or plugged in).

When a UMI Peripheral is moved from one UMI Host to another, it may need some software changes, but will not require any hardware changes (mechanical or electrical).

The following diagram shows an example product that contains 4 UMI Ports :

- One internal (board-to-board) low power Port.
- Two external (ribbon cable) low power Ports.
- One external (ribbon cable) high power Port.

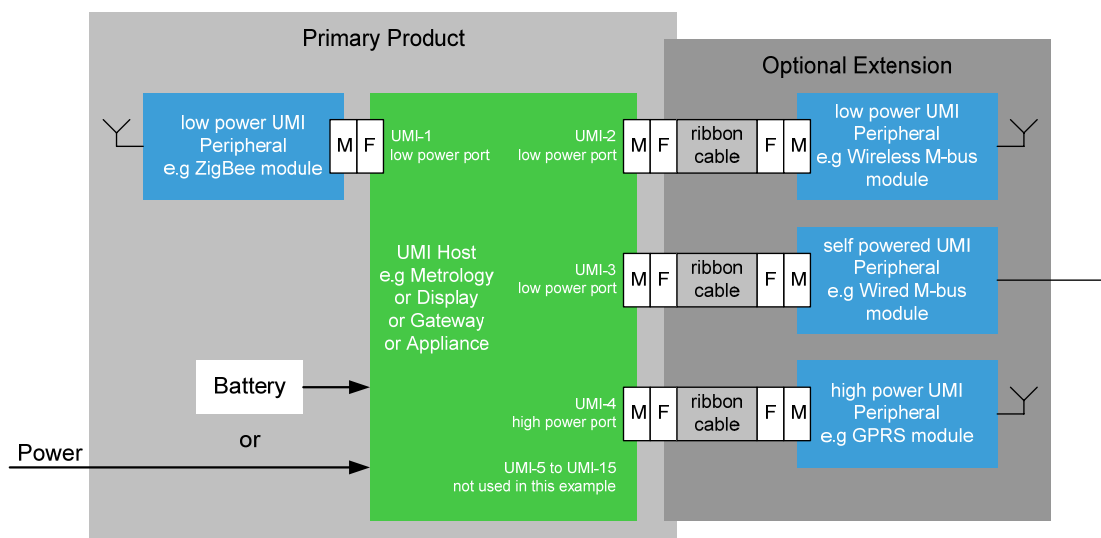

Subject: UMI™ (Universal Metering Interface) Overview

Pin	Name	Type	Direction at UMI Host	Description
1	UMI_VDD	Power	-	Signal voltage level from Host to Peripheral. Also used as power supply to low power Peripherals.
2	UMI_MISO	SPI	Input	SPI data from Peripheral
3	UMI_HVDD	Power	-	Power supply to high power Peripherals. Not connected in low power Host Port or low power Peripheral or self-powered Peripheral (just a capacitor to GND in these cases).
4	UMI_MOSI	SPI	Output	SPI data from Host
5	GND	Power	-	0V
6	UMI_CLK	SPI	Output	SPI clock from Host
7	GND	Power	-	0V
8	UMI_CSB	SPI	Output	SPI chip select from Host, active low
9	UMI_INTB	IO	Input	Interrupt from Peripheral Normally high Negative then Positive edges are active
10	UMI_RSTB	IO	Output	Reset from Host, active low, open drain

The signals are all digital, driven at 0V or UMI_VDD (which is 2.7V to 3.6V).

3.4 Link and Application Layers

UMI has a packet protocol for Link and Application layers. UMI transactions consist of a Command and a Response. The Command can be initiated by the Host or by the Peripheral. This means that although UMI is physically a hierarchical star network, it is operated logically as a peer-to-peer network (between the Host and Peripherals). UMI transactions include error detection and reporting.

3.5 Security

UMI operates an authentication scheme and uses certificate signatures. Every UMI data object has its own read and write access levels. These are set so that access requests are

Subject: UMI™ (Universal Metering Interface) Overview

authorised or rejected as appropriate for various individuals and organisations (e.g Meter Operators and Energy Suppliers).

3.6 UMI codes and data objects

Each UMI data object is identified by a 32-bit UMI code of the form :

- umi.byte3.byte2.byte1.byte0 Each byte is a decimal number, 0-255.
- e.g, umi.1.23.1.103

A UMI data object has one UMI code and can be any of :

- A basic data type (integer or string)
- A structure (of basic data types)
- An array (of basic data types)
- An array of structures

Members of the UMI Alliance are allocated a bank of 64k UMI codes which they can use as they please. e.g a company might be given the UMI bank, umi.1.23. We recommend that the company allocates banks of 256 UMI codes to each new UMI device they develop, e.g umi.1.23.0 for their first UMI device and umi.1.23.1 for the next. The development project team can then allocate the 256 UMI codes to data objects in their device as they please, e.g umi.1.23.1.103.

This scheme does not require ‘manufacturer-specific’ UMI codes. UMI codes will not clash because they are hierarchically managed by the UMI Alliance, the Manufacturers and the project teams. Devices will not be UMI-certified if they use UMI codes outside their allotted UMI banks.

This scheme does mean that some logically-equivalent data objects will be allocated different UMI codes from one manufacturer to another. This does not matter as every UMI Peripheral will translate their UMI codes (from the Peripheral and Host) as required for the particular communications standard being implemented, e.g :

- A ZigBee module may translate between UMI codes and ZigBee Smart Energy data objects.
- A wireless M-bus module may translate between UMI codes and M-bus or DLMS (OBIS) data objects.
- An IEEE 802.15.4 module may translate between UMI codes and ANSI C12.19 data objects.

Every UMI device has a :

- Server datasheet (describing the UMI codes/data objects in that device)
- Client datasheet (describing the UMI codes/data objects this device expects to access in the connected UMI device).

Subject: UMI™ (Universal Metering Interface) Overview

This information is proprietary to the UMI device manufacturer. They can choose whether to make this information publicly available, or only confidentially available when a CDA has been signed.

Note that the UMI interface is open, but the data objects in UMI devices are not. This is an important point that should make the UMI standard more commercially attractive to many manufacturers.

4 UMI Certification

There will be a UMI certification body.

Devices will not be able to use the UMI logo or be declared as UMI devices until the UMI certification body has verified that the device passes all the UMI compliance tests.

5 Benefits

The UMI standard allows metrologically approved meters (e.g MID) to be developed now that can work with a variety of different communications standards, even if they are not fully defined yet.

5.1 Device Manufacturers

Meter, Gateway and Display manufacturers do not have to develop their own communications modules. They can design their products now as UMI Hosts and later choose the UMI module they require from a specialist communications company. This will significantly reduce development costs.

Communications companies can develop their modules now as UMI Peripherals that will immediately access a larger market. The same device can be plugged into many different UMI Hosts. This will lead to larger production volumes and lower unit costs.

5.2 Energy Suppliers

Energy companies and Meter Asset Providers can benefit from lower unit costs and fewer single-source products by specifying that Meters and Communications modules must be UMI-compliant. UMI-enabled (or UMI-inside !) metering devices are more future-proof, which will reduce stranded assets.

5.3 Smart meter rollouts

Smart meter rollouts are planned for many countries. They are all being delayed because:

- People don't want to install anything until everything is specified.

Subject: UMI™ (Universal Metering Interface) Overview

- It is too hard to specify everything without empirical evidence and feedback from large installations (> 100k).
- Consequently people are too scared and everything gets delayed. “Perfection is the enemy of the good !”.

A successful smart meter rollout is likely to consist of :

- Revolutionary rollout first. This will solve 80% of the problem. The solution must contain technical hooks and interfaces to enable growth after the rollout.
- Then evolutionary growth. This will allow the remaining 20% of the problem to be solved over time after the rollout.

UMI is an important enabler to support the above model. It means that :

- Smart-ready meters can be installed now (e.g a UMI-enabled gas meter with a valve but no communications module fitted). Communications modules can be installed in the field later (at the same time as the home gateway is installed), when the communications standards have been chosen.
- When national standards are chosen (e.g UK SRSM, Netherlands NTA, Germany OMS, etc), the main meter roll-out can be achieved by installing UMI-enabled meters (e.g a UMI-enabled gas meter with a valve and communications module fitted). This will enable the meters to be modified in the field, either by upgrading software or by changing the UMI communications module.

6 What next ?

We hope that you will include the UMI ports in your new smart metering products (UMI Hosts) and communications modules (UMI Peripherals). UMI Peripherals will be available for wireless and wired LAN and WAN interfaces (e.g ZigBee, Wireless M-Bus, GPRS, PLC (Power Line Communications)).

If you would like to know more about UMI, the UMI software stack (in C) and UMI test services, please contact Alistair Morfey :

- Alistair.Morfey@CambridgeConsultants.com
- +44-1223-392378 (direct)
- +44-1223-420024 (switchboard)
- www.CambridgeConsultants.com/umi

Cambridge Consultants is a multi-disciplinary engineering design consultancy with 300 people in Cambridge UK and 40 in Boston USA. We sell engineering design services and technology intellectual property. In 2010 we celebrate our 50th anniversary. You can find out more about the company at www.CambridgeConsultants.com. We are available to help you develop your UMI-compliant products.